

INSTRUCTION MANUAL

FREQUENCY CONVERTER

MODEL PFG100-3

KIKUSUI ELECTRONICS CORPORATION

78.8.29

7822221

Power Requirements of this Product

Power requirements of this product have been changed and the relevant sections of the Operation Manual should be revised accordingly.

(Revision should be applied to items indicated by a check mark)

Input voltage

The input voltage of this product is _____ VAC,
and the voltage range is _____ to _____ VAC. Use the product within this range only.

Input fuse

The rating of this product's input fuse is _____ A, _____ VAC, and _____.

WARNING

- To avoid electrical shock, always disconnect the AC power cable or turn off the switch on the switchboard before attempting to check or replace the fuse.
- Use a fuse element having a shape, rating, and characteristics suitable for this product. The use of a fuse with a different rating or one that short circuits the fuse holder may result in fire, electric shock, or irreparable damage.

AC power cable

The product is provided with AC power cables described below. If the cable has no power plug, attach a power plug or crimp-style terminals to the cable in accordance with the wire colors specified in the drawing.

WARNING

- The attachment of a power plug or crimp-style terminals must be carried out by qualified personnel.

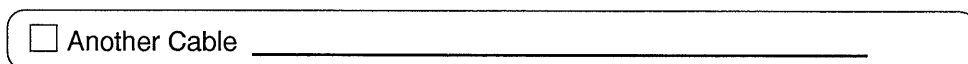
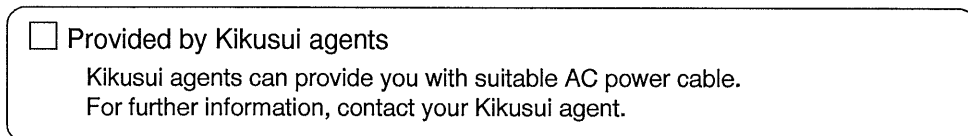
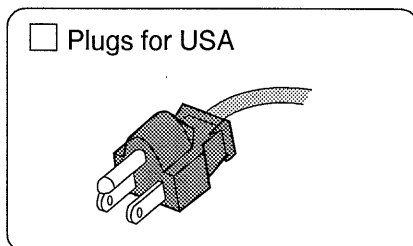
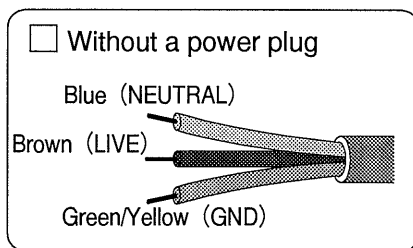

Table of Contents

	<u>Page</u>
1. General	1
2. Features	2
3. Specifications	3
4. Panel Explanation and Block Diagram	5
5. Protection Circuit	10
6. Operation Method	11

7822229

1. General

The PCG100-3 is a compact, precision frequency converter which employs a linear amplifier and supplies a high regulation and low distortion line frequency output with a rating of 300 VA.

The converter employs an AC \rightarrow DC \rightarrow AC conversion system. The amplifier section employs a power amplifier circuit of an excellent linearity and incorporates a feedback loop, thereby providing for the load an ideal sinusoidal-wave output power with high stability and low distortion, being less affected by waveform distortion and noise of the input power line.

The oscillator section has a crystal oscillator which provides a high frequency stability and a CR oscillator of which output frequency is continuously variable. Due to these provisions, the converter can be used best suiting the type of load and other application requirements.

Also, the converter operates safely against starting overload and accidental short circuit. It incorporates an output shut-off circuit for continuous overload and a shut-off prevention circuit for transiential overload of up to about one second when starting the load.

Further, the converter is designed with sufficient allowances for supplying a power for a load which presents a low power factor or which causes a reverse electromotive force.

For heat dissipation, the converter employs a specifically designed cooling package system which ensures efficient and safe operation.

2. Features

- (1) To provide a frequency reference, the converter has a 50 Hz and 60 Hz crystal oscillator and continuously-variable-frequency CR oscillator.
- (2) High frequency stability: 1×10^{-4} (crystal)
- (3) Low output wave distortion: 1 %
- (4) Low line regulation: ± 0.5 %
- (5) Full protective features are incorporated.
- (6) The output is less affected by the input change and noise.
- (7) The regulation is adjustable -- regulation control feature.

79.7.1

782231A

3. Specifications

Model: PCG100-3

Output rating: 300 VA

Input voltage: 100 V $\pm 10\%$

Input frequency: 50/60 Hz

Input phase: Single phase

Output voltage: 90/100/110/120 V by rotary switch

Adjustable output voltage range: $\pm 2\%$

Line regulation: $\pm 0.5\%$

Load regulation: -0.2% +1.0% (with regulation control)

Output waveform distortion: 1% or better

Output frequency: Crystal oscillator ... 50/60 Hz, $5 \times 10^{-4}\%$
CR oscillator 47 ~ 63 Hz, 0.5%

Load power factor: 100% output ... 0.85 ~ 1
80% output ... 0.7

When power factor is less than 0.7, as shown
in the power delecting chart at the end of this
instruction manual.

Apparent input power: Approx. 800 VA (at rated output)

Ambient temperature: 0 ~ +40°C

Ambient humidity: 90% RH or less

External dimensions: 315 W × 140 H × 315 D mm

(Maximum dimensions): 320 W × 165 H × 350 D mm

Weight: Approx. 18 kg

Withstand voltage: Between power input terminal and chassis
..... 20 MΩ or over, with 500 V DC

Accessories: AC cable (1 set)

All specifications are AC 100V output only.

79.7.1

732233A

4. Panel Explanation and Block Diagram

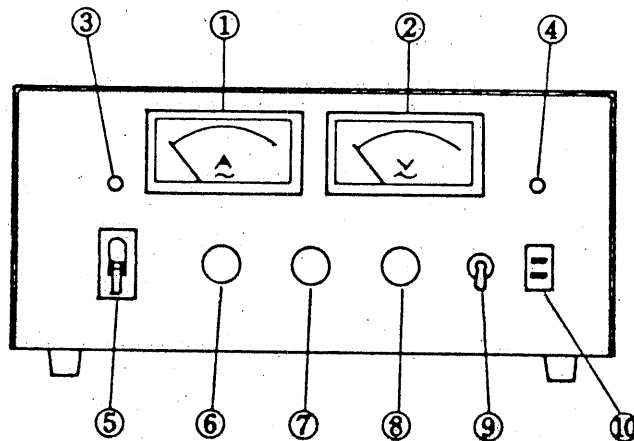

Fig. 1 Front panel

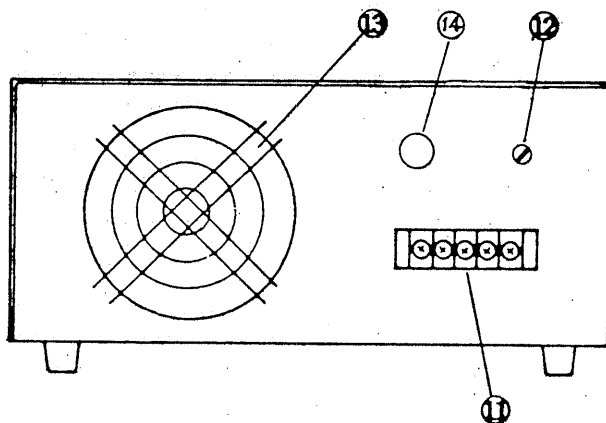

Fig. 2 Rear panel

① Output ammeter:

Indicates the output current. 3.5 A full scale, Class 2.5 (JIS)

② Output voltmeter:

Indicates the output voltage. 150 V full scale, Class 2.5 (JIS)

③ Power pilot:

Green LED (light emitting diode) which turns on when power switch ⑤ is turned on.

79.17.1
PEG100-3
782234A

④ Overload indicator:

Turns on when being overloaded and the output is cut off.

When this LED has turned on, the converter must be reset. For resetting, reduce the load to a state lower than the rating, turn OFF the power switch ⑤ for once and turn it ON again. If this LED does not turn on again in this case, the converter can resume its operation.

Indication "ALARM"

⑤ Power switch:

Input power switch. When thrown to the upper position (ON position), the converter starts providing the power in about one second.

Indication "POWER ON OFF"

⑥ Frequency selection switch:

Selects the output frequency 50 Hz or 60 Hz fixed frequency (crystal oscillator) or 47 Hz ~ 63 Hz variable frequency (CR oscillator).

Indication "50 Hz, 60 Hz, VARIABLE"

⑦ Frequency adjustment knob:

For adjusting the oscillating frequency of CR oscillator within 47 ~ 63 Hz.

Indication "FREQUENCY"

⑧ Output voltage adjustment knob:

For adjusting the output voltage. The voltage increases as this knob is turned clockwise. The adjusting range is $\pm 2\%$ of rated voltage.

Indication "VOLTAGE"

782235

⑨ Output switch:

For ON-OFF control of the output power which is fed to the load.

Indication "OUTPUT ON OFF"

⑩ AC receptacle:

Provides the output power. Can be connected with regular AC plug.

Indication "OUTPUT 100V 300 VA"

⑪ Input/output terminals:

Terminals for input power and output power of the converter. Use 4-mm crimp terminals for wiring to these terminals.

Indication "OUTPUT GND INPUT AC100 V"

⑫ Regulation control:

As this control is turned clockwise, compensation for voltage drop caused by load current is effected. Up to about 1% of voltage drop caused at the rated load in the output power cable can be compensated for.

Indication "REGULATION ADJ"

⑬ Fan motor:

Cools the internal components, especially the power transistors, of the converter.

⑭ Output voltage change switch:

Output voltage change for 90V, 100V, 110V, 120V.

79.7.1

782236A

Block Diagram

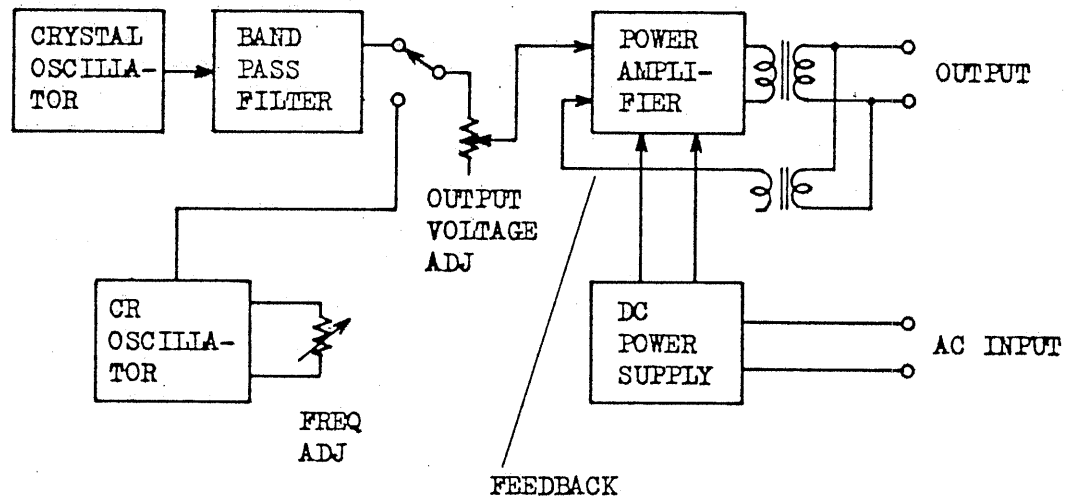

Fig. 3

The five major componential blocks of the converter are as follows:

- (1) DC power supply
- (2) Power amplifier
- (3) Crystal oscillator
- (4) CR oscillator
- (5) Feedback circuit

(1) DC power supply:

Converts the AC input power into a DC power for the power amplifier. Employs a choke input type bridge rectifier circuit which provides an excellent power factor.

782237

(2) Power amplifier:

Provides the AC output power for the load. Employs SEPP (single-ended push-pull) circuit with power transistors of good linearity. Uses a transformer in the output circuit to cut off completely the DC component.

(3) Crystal oscillator:

The oscillating frequency is controlled with a quartz crystal resonator which ensures a high frequency stability. The square-wave output of the oscillator is conditioned by the band pass filter into a sinusoidal wave signal (reference signal). Two modules (50-Hz module and 60 Hz module) are available.

(4) CR oscillator:

Low-distortion CR oscillator, the oscillating frequency of which is continuously variable.

(5) Feedback circuit:

This circuit detects the output voltage and current, and feeds back the detected signal through a unique circuit for output voltage regulation and distortion control. The regulation control circuit is included in this circuit.

5. Protective Features

The converter is incorporated with full protective features against overload and short circuit as follows:

- (1) The converter is designed with a sufficient allowance to withstand such overcurrent as converter startup current or load inrush current. The drive current is limited and the converter presents drop characteristics for a load larger than the rated limit.
- (2) When an output overcurrent has existed for more than about one second, the protecting circuit trips and the output voltage drops. At the same time the relay trips and the output is cut off.
- (3) For a load which presents a reverse electromotive force, the converter output circuit is incorporated with diodes, large capacitors and other surge absorbers.
- (4) When the internal temperature of the converter has risen above a certain limit due to failure of the cooling motor fan or other cause, the thermostat cuts off the input power.

6. Operation Method

- (1) Ensure that the input voltage is AC 100 V $\pm 10\%$. Connect the input and output cables to the INPUT AC100V and OUTPUT terminals of terminal board (11) of the rear panel. The load can be connected also to AC receptacle (10) of the front panel. Output voltage can select four voltages (90/100/110/120 V) by rotary switch (14).
- (2) Select the 50Hz, 60Hz, or VARIABLE position of frequency selector switch (6). When the VARIABLE position is selected, the frequency is continuously variable within a range of 47 ~ 63 Hz by means of FREQUENCY control (7).
- (3) Turn-on the POWER switch (5). The green POWER LED (3) will light.
- (4) The output voltage is adjustable for $\pm 2\%$ by means of VOLTAGE control (8).
- (5) Turn-on the OUTPUT switch (9) (load switch).
- (6) With the REGULATION ADJ potentiometer (12) of the rear panel, the voltage drop in the output cable can be compensated for within a range of -0.2% to $+1.0\%$. The compensation increases as the potentiometer is turned clockwise.
- (7) When the power factor of the load is lower than 0.85, decline the load power as shown in the following illustration.

79.7.1

782240A

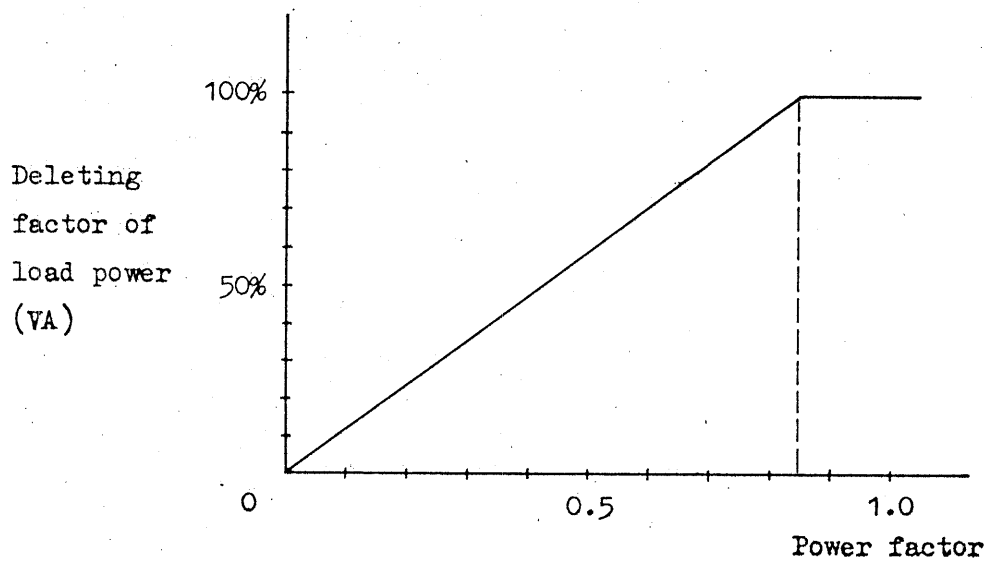

Power deleting chart